

Quick Reference Guide Kurzanleitung Guide de référence rapide Beknopte bedieningshandleiding Guida di riferimento rapido Guía de referencia rápida Guia de referència rápida Краткий справочник

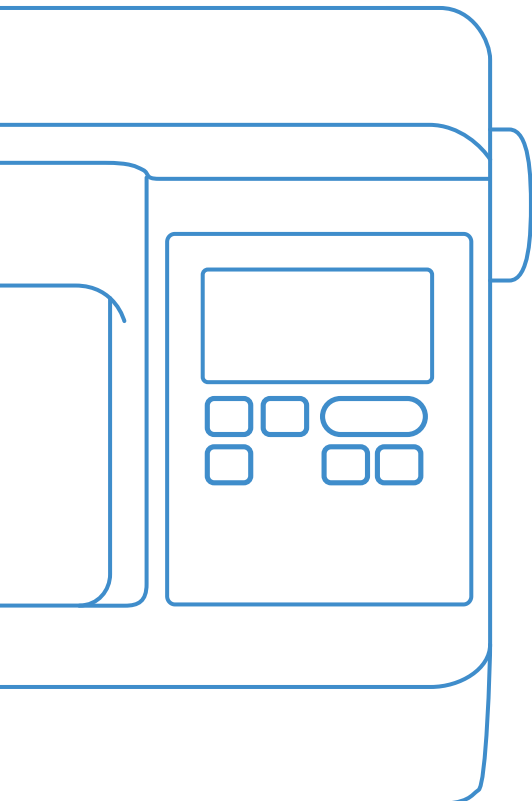

Be sure to read this document before using the machine.
We recommend that you keep this document nearby for future reference.

Lesen Sie dieses Dokument, bevor Sie die Maschine verwenden.
Es wird empfohlen, dieses Dokument griffbereit aufzubewahren, damit Sie jederzeit darin nachschlagen können.

Veillez à lire ce document avant d'utiliser la machine.
Nous vous conseillons de conserver ce document à portée de main pour vous y référer ultérieurement.

Lees dit document voordat u de machine gebruikt.
Houd dit document bij de hand, zodat u het kunt raadplegen.

Leggere questo documento prima di utilizzare la macchina.
Si consiglia di conservare questo documento a portata di mano per un eventuale riferimento futuro.

Lea este documento antes de utilizar la máquina.
Recomendamos que tenga este documento a mano por si necesita consultarlo más adelante.

Certifique-se de ler este documento antes de utilizar a máquina.
Recomendamos guardar este documento em um lugar de fácil acesso para futuras referências.

Обязательно прочитайте этот документ перед началом работы на машине!
Рекомендуется хранить данный документ в удобном месте, чтобы он был доступен для справок.

Before using your machine for the first time please read the “IMPORTANT SAFETY INSTRUCTIONS” in the Operation Manual.

Refer to the Operation Manual for detailed instructions.

In this guide, English screens are used for basic explanations.

For details on the built-in embroidery patterns, refer to the Embroidery Design Guide.

Bevor Sie die Maschine zum ersten Mal verwenden, lesen Sie bitte „WICHTIGE SICHERHEITSHINWEISE“ in der Bedienungsanleitung.

Ausführliche Hinweise finden Sie in der Bedienungsanleitung.

In dieser Anleitung werden für die grundlegenden Erläuterungen englischsprachige Bildschirme verwendet.

Weitere Informationen zu den internen Stickmustern finden Sie in dem Stickmuster-Katalog.

Avant d'utiliser votre machine pour la première fois, veuillez lire les « INSTRUCTIONS DE SÉCURITÉ IMPORTANTES » indiquées dans le Manuel d'instructions.

Reportez-vous au Manuel d'instructions pour des informations détaillées.

Les écrans de ce guide sont en anglais pour les explications de base.

Pour plus de détails sur les motifs de broderie intégrés, consultez le guide de motifs de broderie.

Lees – voordat u de machine de eerste keer gebruikt – de “BELANGRIJKE VEILIGHEIDSinSTRUCTIES” in de Bedieningshandleiding.

In de Bedieningshandleiding vindt u uitvoerige aanwijzingen.

In deze gids worden Engelse schermen gebruikt bij de uitleg van basisbewerkingen.

Meer bijzonderheden over de ingebouwde borduurpatronen vindt u in de Borduurmotieven handleiding.

Prima di utilizzare la macchina per la prima volta, leggere “IMPORTANTI ISTRUZIONI DI SICUREZZA” nel Manuale di istruzioni.

Per le istruzioni dettagliate, consultare il Manuale di istruzioni.

Nella presente guida si utilizzano le schermate in inglese per le spiegazioni di base.

Per i dettagli sui motivi da ricamo incorporati, consultare la Guida ai disegni da ricamo.

Antes de utilizar la máquina por primera vez, lea las “INSTRUCCIONES DE SEGURIDAD IMPORTANTES” en el Manual de instrucciones.

Consulte las instrucciones detalladas en el Manual de instrucciones.

En esta guía, para las explicaciones básicas se utilizan pantallas en inglés.

Para más detalles acerca de los patrones de bordado embutidos, consulte la Guía de diseños de bordado.

Antes de utilizar a sua máquina pela primeira vez, leia as “INSTRUÇÕES DE SEGURANÇA IMPORTANTES” no Manual de Operações.

Consulte o Manual de Operações para obter instruções detalhadas.

Neste manual, as telas em inglês são usadas para as explicações básicas.

Para obter detalhes sobre os padrões de bordado incluídos, consulte o Guia de Design de Bordado.

Перед первым использованием машины прочитайте раздел “ВАЖНЫЕ ИНСТРУКЦИИ ПО БЕЗОПАСНОСТИ” в Руководстве пользователя.

Подробные инструкции см. в Руководстве пользователя.

В данном руководстве в качестве иллюстраций используются англоязычные экраны.

Подробная информация о встроенных рисунках для вышивания приведена в Руководстве по дизайнам для вышивания.

Contents

Accessories	3
◆ Included Accessories	3
◆ Optional Accessories	3
Winding/Installing the Bobbin	11
Upper Threading	13
Preparing to Embroider	15
Selecting Embroidery Patterns	17

Table des matières

Accessoires	5
◆ Accessoires inclus	5
◆ Accessoires en option	5
Bobinage/installation de la canette	11
Enfilage supérieur	13
Préparation de la broderie	15
Sélection des motifs de broderie	17

Sommario

Accessori	7
◆ Accessori in dotazione	7
◆ Accessori opzionali	7
Avvolgimento/Installazione della spolina	11
Infilatura superiore	13
Preparativi per il ricamo	15
Selezione di ricami	17

Índice

Acessórios	9
◆ Acessórios incluídos	9
◆ Acessórios opcionais	9
Encher/Instalar a bobina	11
Passagem da linha superior	13
Preparação para bordar	15
Seleção de padrões de bordado	17

Inhalt

Zubehör	3
◆ Mitgeliefertes Zubehör	3
◆ Optionales Zubehör	3
Aufwickeln/Einsetzen der Spule	11
Einfädeln des Oberfadens	13
Vorbereitung zum Sticken	15
Auswählen von Stickmustern	17

Inhoudsopgave

Accessoires	5
◆ Bijgeleverde accessoires	5
◆ Optionele accessoires	5
Spoel opwinden/installeren	11
Inrijgen van de bovendraad	13
Vorbereidingen voor borduren	15
Borduurpatronen selecteren	17

Contenido

Accesorios	7
◆ Accesorios incluidos	7
◆ Accesorios opcionales	7
Devanar/colocar la bobina	11
Hilo superior	13
Preparativos para bordar	15
Seleccionar patrones de bordado	17

Содержание

Принадлежности	9
◆ Принадлежности в комплекте поставки	9
◆ Дополнительные принадлежности	9
Намотка/установка шпульки	11
Заправка верхней нити	13
Подготовка к вышиванию	15
Выбор рисунков для вышивания	17

◆ Included Accessories

No.	Part Name	Part Code	
		Americas	Others
1	Embroidery foot "Q" (on machine)	XD0474-151	
2	Needle set	X59535-051	
3	Bobbin (4) (One is on machine.)	SA156*3	SFB: XA5539-151
4	Seam ripper	XF4967-001	
5	Scissors	XC1807-121	
6	Cleaning brush	X59476-051	
7	Screwdriver (large)	XC8349-021	
8	Screwdriver (small)	X55468-051	
9	Disc-shaped screwdriver	XC1074-051	
10	Spool cap (large)	130012-024	
11	Spool cap (medium) (on machine)	XE1372-001	
12	Spool cap (small)	130013-124	
13	Thread spool insert (mini king thread spool)	XA5752-121	
14	Spool net	XA5523-020	
15	Bobbin case (no color on the screw) (on machine)	XG0871-001	
16	Embroidery frame set (large) 18 cm (H) × 13 cm (W) (7 inches (H) × 5 inches (W))	SA444	EF84: XF1080-001
17	Embroidery frame set (medium) 10 cm (H) × 10 cm (W) (4 inches (H) × 4 inches (W))	SA443	EF83: XG2108-001
18	Poly 90 weight bobbin thread	EBT-PE	EBT-PEN: XC5996-001
19	Accessory bag	XC4487-021	
20	Dust cover	XG5208-001	
21	Operation Manual	Contact your authorized Brother dealer.	
22	Quick Reference Guide		
23	Embroidery Design Guide		

*3 SA156 is Class15 type bobbin.

◆ Mitgeliefertes Zubehör

Nr.	Teilebezeichnung	Bestellnummer	
		Nord- und Südamerika	Andere
1	Stickfuß „Q“ (an der Maschine)	XD0474-151	
2	Nadelsatz	X59535-051	
3	Spule (4) (Eine ist in der Maschine.)	SA156*3	SFB: XA5539-151
4	Pfeiltrenner	XF4967-001	
5	Schere	XC1807-121	
6	Reinigungspinsel	X59476-051	
7	Schraubendreher (groß)	XC8349-021	
8	Schraubendreher (klein)	X55468-051	
9	Scheibenförmiger Schraubendreher	XC1074-051	
10	Garnrollenkappe (groß)	130012-024	
11	Garnrollenkappe (mittel) (in der Maschine)	XE1372-001	
12	Garnrollenkappe (klein)	130013-124	
13	Garnrollenkappeneinsatz (Mini King Garnrolle)	XA5752-121	
14	Spulennetz	XA5523-020	
15	Spulenkapsel (ohne Schraubenmarkierung) (in der Maschine)	XG0871-001	
16	Stickrahmenset (groß) 18 cm (H) × 13 cm (B) (7 Zoll (H) × 5 Zoll (B))	SA444	EF84: XF1080-001
17	Stickrahmenset (mittel) 10 cm (H) × 10 cm (B) (4 Zoll (H) × 4 Zoll (B))	SA443	EF83: XG2108-001
18	Unterfaden der Gewichtsklasse Poly 90	EBT-PE	EBT-PEN: XC5996-001
19	Zubehörtasche	XC4487-021	
20	Staubabdeckung	XG5208-001	
21	Bedienungsanleitung	Wenden Sie sich an Ihr Brother-Fachgeschäft.	
22	Kurzanleitung		
23	Stickmuster-Katalog		

*3 SA156 ist eine Class15-Spule.

◆ Optional Accessories

The following are available as optional accessories to be purchased separately from your authorized Brother dealer.

No.	Part Name	Part Code	
		Americas	Others
1	Embroidery frame set (extra large (multi-position)) 30 cm (H) × 13 cm (W) (12 inches (H) × 5 inches (W))	SA445	EF85: XG2203-001
2	Embroidery frame set (small) 2 cm (H) × 6 cm (W) (1 inch (H) × 2-1/2 inches (W))	SA442	EF82: XG2147-001
3	Stabilizer material for embroidery	SA519	BM3: XE0806-001
4	Water soluble stabilizer	SA520	BM5: XE0615-001

◆ Optionales Zubehör

Folgendes Sonderzubehör ist separat bei Ihrem Brother-Vertragshändler erhältlich.

Nr.	Teilebezeichnung	Bestellnummer	
		Nord- und Südamerika	Andere
1	Stickrahmenset (extragroß (Mehrfachposition)) 30 cm (H) × 13 cm (B) (12 Zoll (H) × 5 Zoll (B))	SA445	EF85: XG2203-001
2	Stickrahmenset (klein) 2 cm (H) × 6 cm (B) (1 Zoll (H) × 2-1/2 Zoll (B))	SA442	EF82: XG2147-001
3	Unterlegmaterial für Stickereien	SA519	BM3: XE0806-001
4	Wasserlösliche Stickfolie	SA520	BM5: XE0615-001

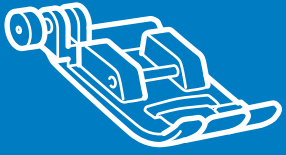

Accessoires

Accessoires

◆ Accessoires inclus

◆ Bijgeleverde accessoires

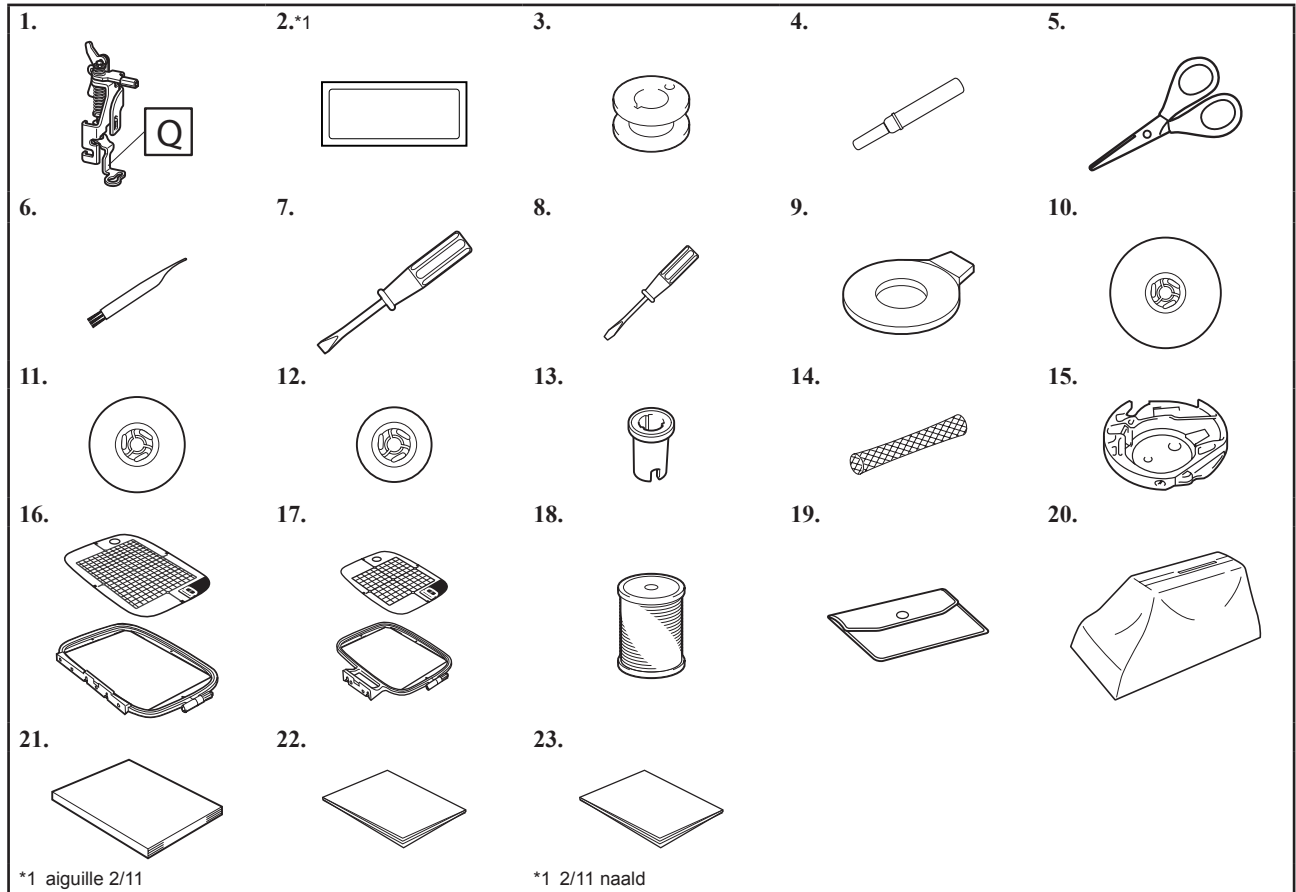

◆ Accessoires en option

◆ Optionele accessoires

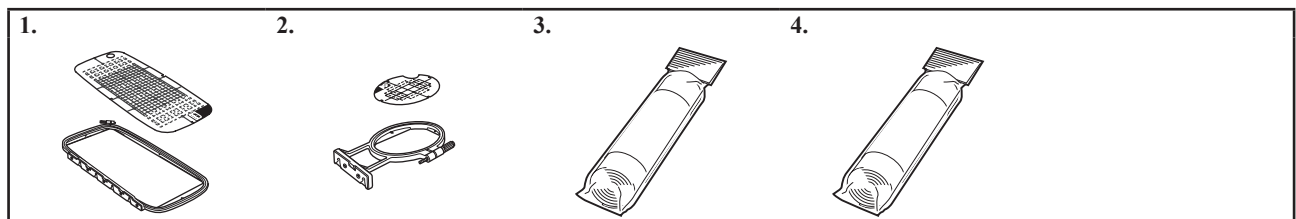

◆ Accessoires inclus

N°	Nom de la pièce	Code de la pièce	
		Continent américain	Autres
1	Pied de broderie « Q » (sur la machine)	XD0474-151	
2	Jeu d'aiguilles	X59535-051	
3	Canette (4) (L'une se trouve sur la machine.)	SA156 ^{*3}	SFB: XA5539-151
4	Découpeur	XF4967-001	
5	Ciseaux	XC1807-121	
6	Brosse de nettoyage	X59476-051	
7	Tournevis (grand)	XC8349-021	
8	Tournevis (petit)	X55468-051	
9	Tournevis en forme de disque	XC1074-051	
10	Couvercle de bobine (grand)	130012-024	
11	Couvercle de bobine (moyen) (sur la machine)	XE1372-001	
12	Couvercle de bobine (petit)	130013-124	
13	Centre amovible pour bobine de fil (bobine de fil mini/très grande)	XA5752-121	
14	Filet de la bobine	XA5523-020	
15	Boîtier de la canette (sans couleur sur la vis) (sur la machine)	XG0871-001	
16	Jeu de cadre de broderie (grand) H 18 cm × L 13 cm (H 7" / pouces × L 5" / pouces)	SA444	EF84: XF1080-001
17	Jeu de cadre de broderie (moyen) H 10 cm × L 10 cm (H 4" / pouces × L 4" / pouces)	SA443	EF83: XG2108-001
18	Fil de canette à broder poly n°90	EBT-PE	EBT-PEN: XC5996-001
19	Sac d'accessoires	XC4487-021	
20	Housse	XG5208-001	
21	Manuel d'instructions	Contactez votre revendeur Brother agréé.	
22	Guide de référence rapide		
23	Guide de motifs de broderie		

*3 SA156 est une canette de catégorie 15.

◆ Bijgeleverde accessoires

Nr.	Onderdeel	Onderdeelcode	
		Het Amerikaanse continent	Overige regio's
1	Borduurvoet "Q" (op machine)	XD0474-151	
2	Naaldsetje	X59535-051	
3	Spoel x 4 (één is op de machine geplaatst.)	SA156 ^{*3}	SFB: XA5539-151
4	Tornmesje	XF4967-001	
5	Schaar	XC1807-121	
6	Schoonmaakborsteltje	X59476-051	
7	Schroevendraaier (groot)	XC8349-021	
8	Schroevendraaier (klein)	X55468-051	
9	Schijfvormige schroevendraaier	XC1074-051	
10	Kloshouder (groot)	130012-024	
11	Kloshouder (medium) (op machine)	XE1372-001	
12	Kloshouder (klein)	130013-124	
13	Garenklos hulpinzet (bij mini- of kingsize garenklos)	XA5752-121	
14	Klosnetje	XA5523-020	
15	Spoelhuis (geen kleur op de schroef) (op machine)	XG0871-001	
16	Borduurraamset (groot) 18 cm (H) × 13 cm (B) (7 inch (H) × 5 inch (B))	SA444	EF84: XF1080-001
17	Borduurraamset (medium) 10 cm (H) × 10 cm (B) (4 inch (H) × 4 inch (B))	SA443	EF83: XG2108-001
18	Poly onderdraad, dikte 90	EBT-PE	EBT-PEN: XC5996-001
19	Accessoires tasje	XC4487-021	
20	Stofhoes	XG5208-001	
21	Bedieningshandleiding	Neem contact op met uw erkende Brother-dealer.	
22	Beknopte bedieningshandleiding		
23	Borduurontwerpen bedieningshandleiding		

*3 SA156 is een spoeltype van klasse 15.

◆ Accessoires en option

Les éléments suivants sont des accessoires en option vendus séparément par votre revendeur Brother agréé.

N°	Nom de la pièce	Code de la pièce	
		Continent américain	Autres
1	Jeu de cadre de broderie (très grand, positions multiples) H 30 cm × L 13 cm (H12" / pouces × L 5" / pouces)	SA445	EF85: XG2203-001
2	Jeu de cadre de broderie (petit) H 2 cm × L 6 cm (H 1" / pouce × L 2-1/2" / pouces)	SA442	EF82: XG2147-001
3	Renfort de broderie	SA519	BM3: XE0806-001
4	Renfort de broderie soluble	SA520	BM5: XE0615-001

◆ Optionele accessoires

Optionele accessoires, apart verkrijgbaar bij uw officiële Brother dealer.

Nr.	Onderdeel	Onderdeelcode	
		Het Amerikaanse continent	Overige regio's
1	Borduurraamset (extra groot, meerdere standen) 30 cm (H) × 13 cm (B) (12 inch (H) × 5 inch (B))	SA445	EF85: XG2203-001
2	Borduurraamset (klein) 2 cm (H) × 6 cm (B) (1 inch (H) × 2-1/2 inch (B))	SA442	EF82: XG2147-001
3	Steunstof voor borduurwerk	SA519	BM3: XE0806-001
4	Wateroplosbare steunstof	SA520	BM5: XE0615-001

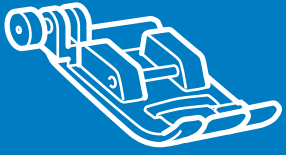

Accessori

Accesorios

◆ Accessori in dotazione

◆ Accesorios incluidos

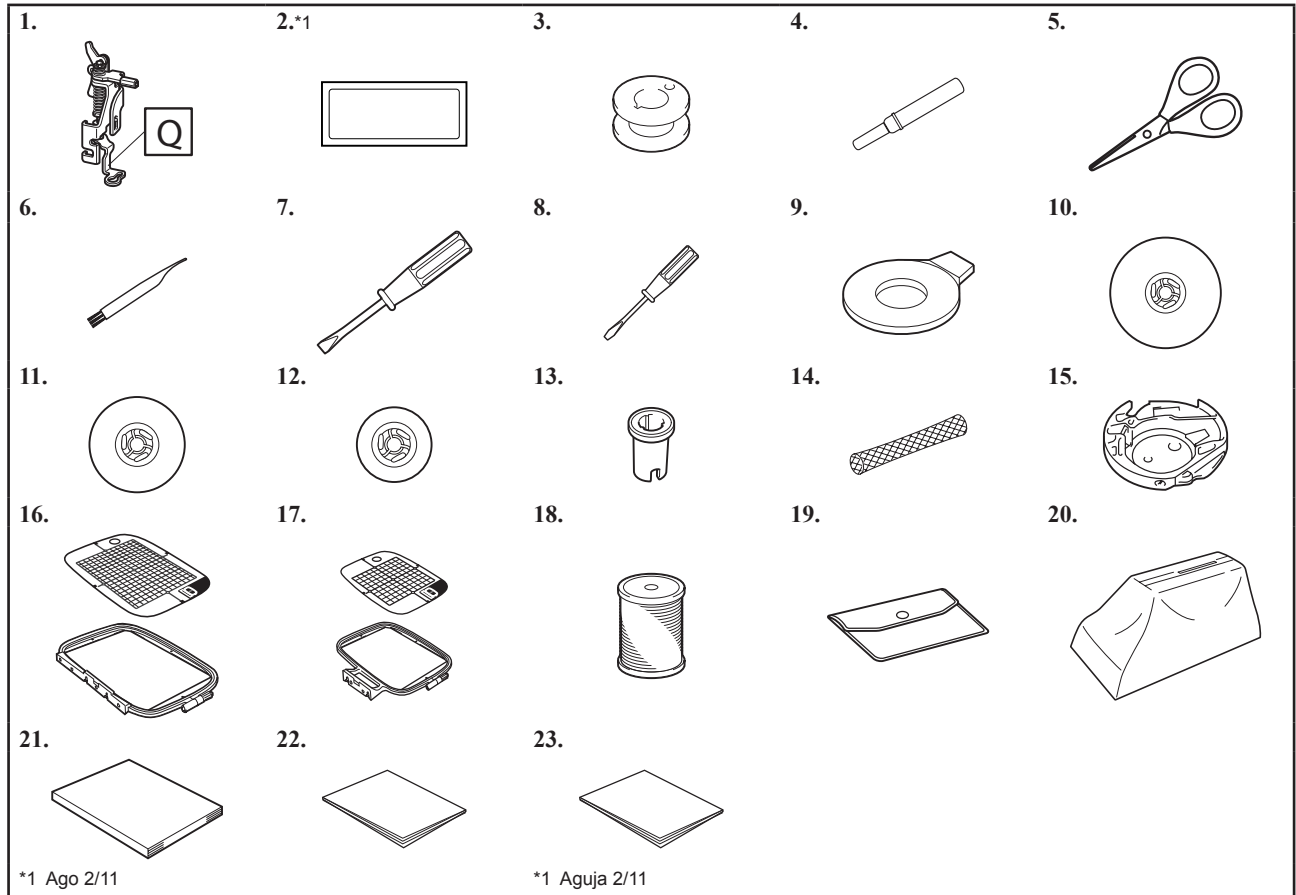

◆ Accessori opzionali

◆ Accesorios opcionales

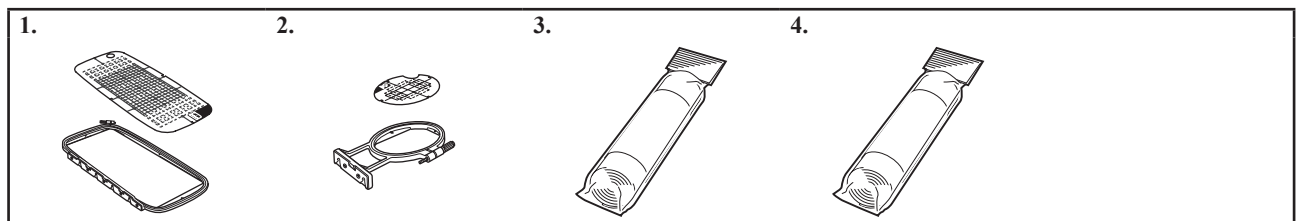

◆ Accessori in dotazione

N°	Nome parte	Codice parte	
		Americhe	Varie
1	Piedino per ricamo "Q" (sulla macchina)	XD0474-151	
2	Set di aghi	X59535-051	
3	Spolina (4) (una è sulla macchina.)	SA156*3	SFB: XA5539-151
4	Taglia asole	XF4967-001	
5	Forbici	XC1807-121	
6	Spazzolino di pulizia	X59476-051	
7	Cacciavite (grande)	XC8349-021	
8	Cacciavite (piccolo)	X55468-051	
9	Cacciavite a disco	XC1074-051	
10	Fermo per rocchetto (grande)	130012-024	
11	Fermo per rocchetto (medio) (sulla macchina)	XE1372-001	
12	Fermo per rocchetto (piccolo)	130013-124	
13	Inserto per rocchetto di filo (rocchetto di filo mini-extra large)	XA5752-121	
14	Retina	XA5523-020	
15	Cestello della spolina (nessun colore sulla vite) (sulla macchina)	XG0871-001	
16	Set telaio per ricamo (grande) 18 cm (A) × 13 cm (L) (7 in (A) × 5 in (L))	SA444	EF84: XF1080-001
17	Set telaio per ricamo (medio) 10 cm (A) × 10 cm (L) (4 in (A) × 4 in (L))	SA443	EF83: XG2108-001
18	Filo della spolina di poliestere, peso 90	EBT-PE	EBT-PEN: XC5996-001
19	Borsa accessori	XC4487-021	
20	Copertura parapolvere	XG5208-001	
21	Manuale di istruzioni	Contattare il proprio rivenditore Brother autorizzato.	
22	Guida di riferimento rapido		
23	Guida ai ricami		

*3 SA156 è una spolina del tipo Classe 15.

◆ Accesorios incluidos

N°	Nombre de la pieza	Código de la pieza	
		América	Otros
1	Pie de bordado "Q" (en la máquina)	XD0474-151	
2	Juego de agujas	X59535-051	
3	Bobina (4) (Una está colocada en la máquina.)	SA156*3	SFB: XA5539-151
4	Abreojales	XF4967-001	
5	Tijeras	XC1807-121	
6	Cepillo de limpieza	X59476-051	
7	Destornillador (grande)	XC8349-021	
8	Destornillador (pequeño)	X55468-051	
9	Destornillador de disco	XC1074-051	
10	Tapa del carrete (grande)	130012-024	
11	Tapa del carrete (mediana) (en la máquina)	XE1372-001	
12	Tapa de carrete (pequeña)	130013-124	
13	Inserción del carrete de hilo (carrete de hilo "mini king")	XA5752-121	
14	Red para carrete	XA5523-020	
15	Caja de la bobina (sin color en el tornillo) (en la máquina)	XG0871-001	
16	Juego de bastidor de bordado (grande) 18 cm (Alt.) × 13 cm (Anch.) (7 pulgadas (Alt.) × 5 pulgadas (Anch.))	SA444	EF84: XF1080-001
17	Juego de bastidor de bordado (mediano) 10 cm (Alt.) × 10 cm (Anch.) (4 pulgadas (Alt.) × 4 pulgadas (Anch.))	SA443	EF83: XG2108-001
18	Hilo de la bobina de gramaje poly 90	EBT-PE	EBT-PEN: XC5996-001
19	Bolsa de accesorios	XC4487-021	
20	Funda	XG5208-001	
21	Manual de instrucciones	Póngase en contacto con su distribuidor Brother autorizado.	
22	Guía de referencia rápida		
23	Guía de diseños de bordado		

*3 SA156 Es de bobina clase tipo 15.

◆ Accessori opzionali

Di seguito si elencano i componenti disponibili come accessori opzionali da acquistare separatamente presso il proprio rivenditore Brother autorizzato.

N°	Nome parte	Codice parte	
		Americhe	Varie
1	Set telaio per ricamo (extra large (multiposizione)) 30 cm (A) × 13 cm (L) (12 in (A) × 5 in (L))	SA445	EF85: XG2203-001
2	Set telaio per ricamo (piccolo) 2 cm (A) × 6 cm (L) (1 in (A) × 2-1/2 in (L))	SA442	EF82: XG2147-001
3	Materiale stabilizzatore per ricamo	SA519	BM3: XE0806-001
4	Stabilizzatore solubile in acqua	SA520	BM5: XE0615-001

◆ Accesorios opcionales

En la tabla siguiente se presentan los accesorios opcionales disponibles que pueden adquirirse por separado en un distribuidor de Brother autorizado.

N°	Nombre de la pieza	Código de la pieza	
		América	Otros
1	Juego de bastidor de bordado (extra grande (varias posiciones)) 30 cm (Alt.) × 13 cm (Anch.) (12 pulgadas (Alt.) × 5 pulgadas (Anch.))	SA445	EF85: XG2203-001
2	Juego de bastidor de bordado (pequeño) 2 cm (Alt.) × 6 cm (Anch.) (1 pulgada (Alt.) × 2-1/2 pulgadas (Anch.))	SA442	EF82: XG2147-001
3	Material estabilizador para el bordado	SA519	BM3: XE0806-001
4	Estabilizador soluble en agua	SA520	BM5: XE0615-001

◆ Acessórios incluídos

N°	Nome da peça	Código da peça	
		Américas	Outros
1	Calçador de bordar "Q" (na máquina)	XD0474-151	
2	Conjunto de agulhas	X59535-051	
3	Bobina (4) (Uma está na máquina.)	SA156*3	SFB: XA5539-151
4	Abridor de costura	XF4967-001	
5	Tesoura	XC1807-121	
6	Escova de limpeza	X59476-051	
7	Chave de fenda (grande)	XC8349-021	
8	Chave de fenda (pequena)	X55468-051	
9	Chave de fenda em forma de disco	XC1074-051	
10	Tampa do carretel (grande)	130012-024	
11	Tampa do carretel (média) (na máquina)	XE1372-001	
12	Tampa do carretel (pequena)	130013-124	
13	Inserto do carretel (minicarretel principal)	XA5752-121	
14	Redinha do carretel	XA5523-020	
15	Caixa da bobina (sem cor no parafuso) (na máquina)	XG0871-001	
16	Conjunto de bastidor para bordados (grande) 18 cm (A) × 13 cm (L) (7 polegadas (A) × 5 polegadas (L))	SA444	EF84: XF1080-001
	Conjunto de bastidor para bordados (médio) 10 cm (A) × 10 cm (L) (4 polegadas (A) × 4 polegadas (L))	SA443	EF83: XG2108-001
18	Linha de bobina com peso Poly 90	EBT-PE	EBT-PEN: XC5996-001
19	Bolsa de acessórios	XC4487-021	
20	Capa contra pó	XG5208-001	
21	Manual de Operações	Entre em contato com o seu revendedor autorizado	
22	Guia de referência rápida	Brother.	
23	Guia de desenho de bordado	Brother.	

*3 SA156 é um tipo de bobina da classe 15.

◆ Принадлежности в комплекте поставки

№	Наименование	Код изделия	
		Америка	Другие
1	Лапка для вышивания "Q" (установлен на машине)	XD0474-151	
2	Набор игл	X59535-051	
3	Шпулька (4 шт.) (одна из них установлена на машине.)	SA156*3	SFB: XA5539-151
4	Вспарыватель для петель	XF4967-001	
5	Ножницы	XC1807-121	
6	Щеточка для очистки	X59476-051	
7	Отвертка (большая)	XC8349-021	
8	Отвертка (малая)	X55468-051	
9	Дискообразная отвертка	XC1074-051	
10	Колпачок катушки (большой)	130012-024	
11	Колпачок катушки (средний) (установлен на машине)	XE1372-001	
12	Колпачок катушки (малый)	130013-124	
13	Вставка для катушки с нитью (катушки Mini-King)	XA5752-121	
14	Сетка для катушки	XA5523-020	
15	Шпульный колпачок (без цветовой маркировки на винте) (установлен на машине)	XG0871-001	
16	Набор пялец (больших), 18 × 13 см (В × Ш)	SA444	EF84: XF1080-001
17	Набор пялец (средних), 10 × 10 см (В × Ш)	SA443	EF83: XG2108-001
18	Нижняя нить Poly 90wt	EBT-PE	EBT-PEN: XC5996-001
19	Сумка для принадлежностей	XC4487-021	
20	Пылезащитный чехол	XG5208-001	
21	Руководство пользователя	Обратитесь к официальному дилеру Brother.	
22	Краткий справочник		
23	Руководство по дизайнам для вышивания		

*3 SA156 представляет собой шпульку типа Class15.

◆ Acessórios opcionais

Os acessórios a seguir são opcionais e devem ser adquiridos separadamente em um revendedor autorizado da Brother.

N°	Nome da peça	Código da peça	
		Américas	Outros
1	Conjunto de bastidor para bordados (extragrande (multiposição)) 30 cm (A) × 13 cm (L) (12 polegadas (A) × 5 polegadas (L))	SA445	EF85: XG2203-001
2	Conjunto de bastidor para bordados (pequeno) 2 cm (A) × 6 cm (L) (1 polegadas (A) × 2-1/2 polegadas (L))	SA442	EF82: XG2147-001
3	Entretela estabilizadora para bordado	SA519	BM3: XE0806-001
4	Entretela solúvel em água	SA520	BM5: XE0615-001

◆ Дополнительные принадлежности

Перечисленные ниже дополнительные принадлежности можно приобрести отдельно у официального дилера Brother.

№	Наименование	Код изделия	
		Америка	Другие
1	Набор пялец (сверхбольших (многопозиционных)), 30 × 13 см (В × Ш)	SA445	EF85: XG2203-001
2	Набор пялец (малых), 2 × 6 см (В × Ш)	SA442	EF82: XG2147-001
3	Стабилизирующий материал для вышивания	SA519	BM3: XE0806-001
4	Растворимый в воде стабилизирующий материал	SA520	BM5: XE0615-001



Winding/Installing the Bobbin

Aufwickeln/Einsetzen der Spule

Bobinage/installation de la canette

Spool opwinden/installeren

Avvolgimento/Installazione della spolina

Devanar/colocar la bobina

Encher/Instalar a bobina

Намотка/установка шпульки

Follow the steps below in numerical order. Refer to the Operation Manual for detailed instructions.
 Führen Sie die folgenden Schritte in der numerischen Reihenfolge aus. Ausführliche Hinweise finden Sie in der Bedienungsanleitung.
 Respectez les étapes ci-dessous, dans l'ordre numérique. Reportez-vous au Manuel d'instructions pour des informations détaillées.
 Volg onderstaande stappen in numerieke volgorde. In de Bedieningshandleiding vindt u uitvoerige aanwijzingen.
 Seguire i passaggi di seguito, in ordine numerico. Per le istruzioni dettagliate, consultare il Manuale di istruzioni.
 Siga los pasos descritos a continuación, en orden numérico. Consulte las instrucciones detalladas en el Manual de instrucciones.
 Siga as etapas abaixo, em ordem numérica. Consulte o Manual de Operações para obter instruções detalhadas.
 Выполните описанные ниже действия по порядку номеров. Подробные инструкции см. в Руководстве пользователя.

Use only the included bobbin or bobbins of the same type.
 Verwenden Sie nur die im Lieferumfang enthaltene Spule oder Spulen vom selben Typ.
 N'utilisez que la canette fournie ou des canettes du même type.
 Gebruik uitsluitend de bijgeleverde spool of spoelen van hetzelfde type.
 Utilizzare solo la bobina o le bobine in dotazione dello stesso tipo.
 Utilice solo la bobina incluida, o bobinas del mismo tipo.
 Somente use a bobina incluída ou bobinas do mesmo tipo.
 Используйте только прилагаемые шпульки или шпульки того же типа.

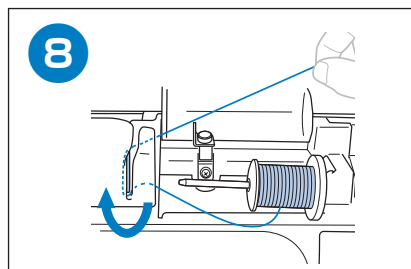
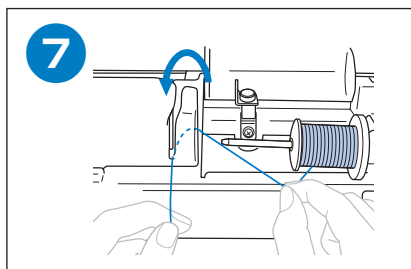
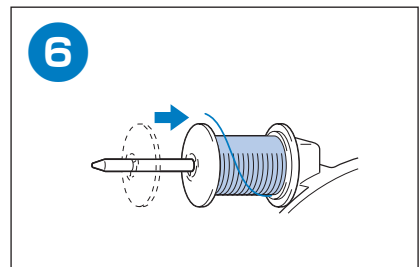
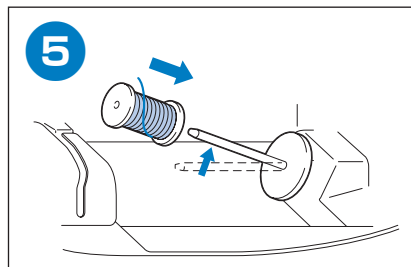
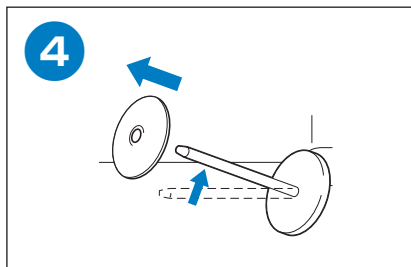
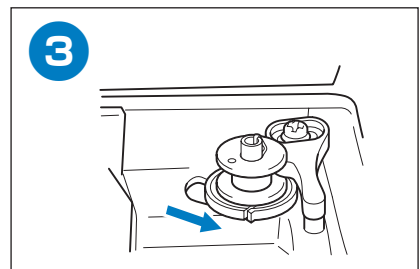
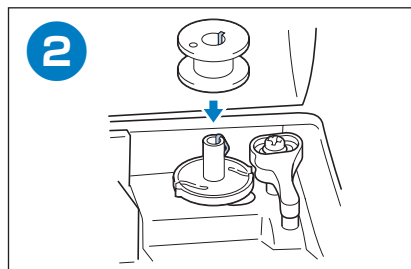
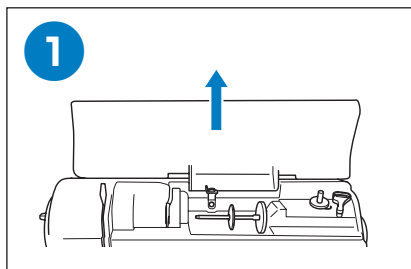
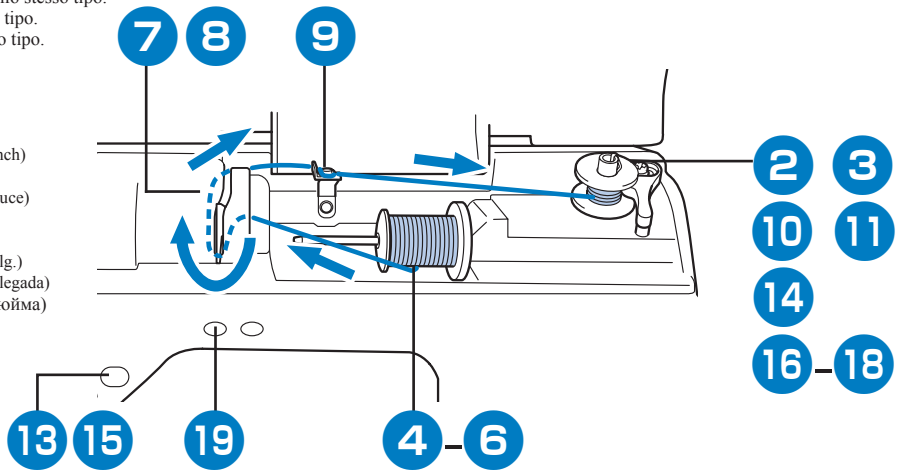
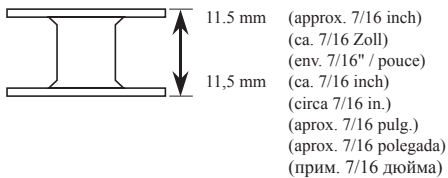

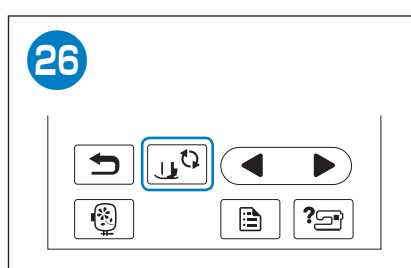
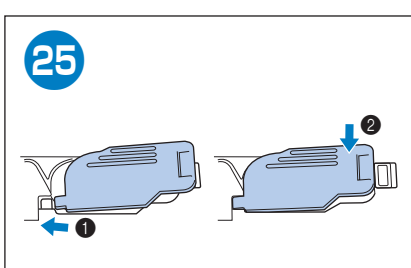
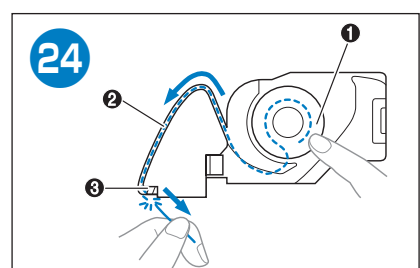
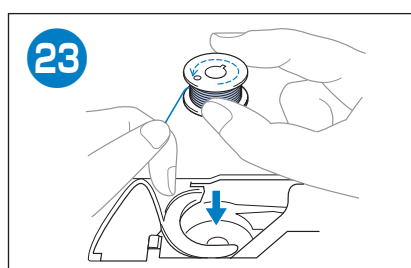
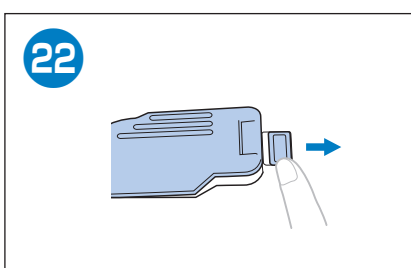
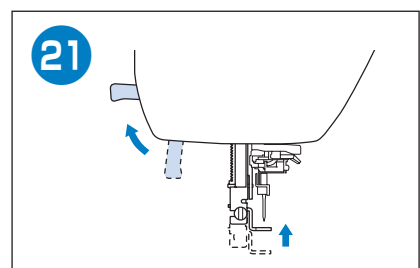
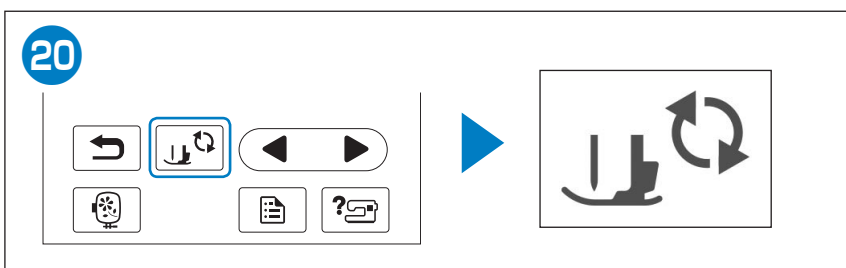
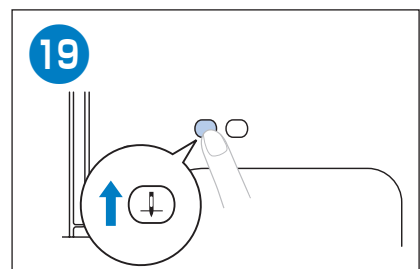
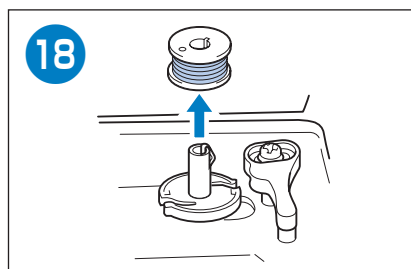
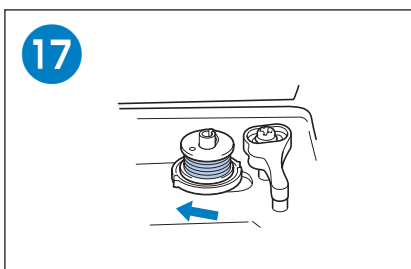
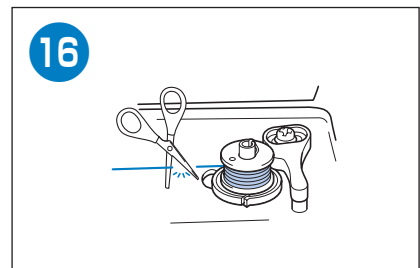
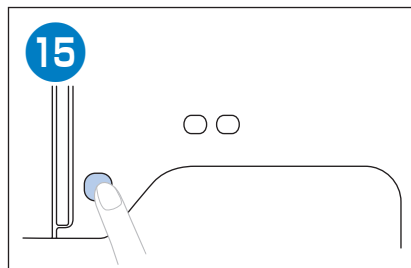
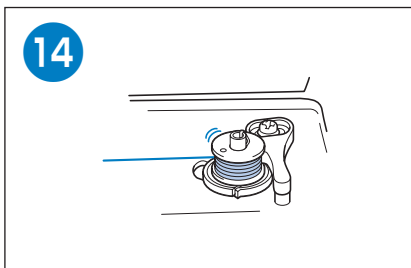
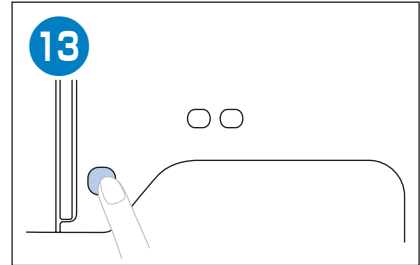
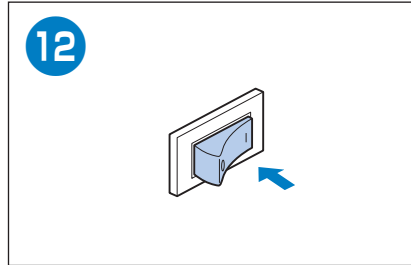
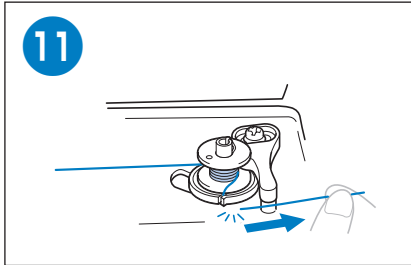
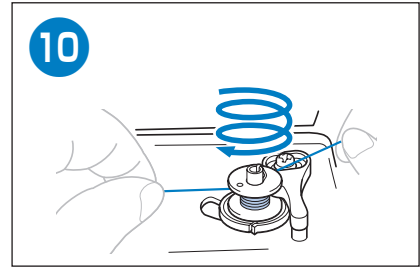
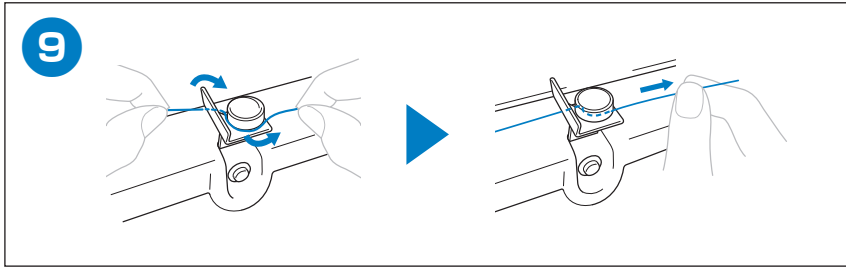



Upper Threading
Einfädeln des Oberfadens
Enfilage supérieur
Inrijgen van de bovendraad
Infilatura superiore
Hilo superior
Passagem da linha superior
Заправка верхней нити

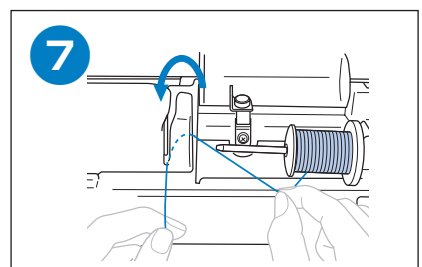
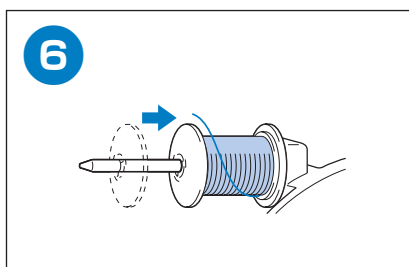
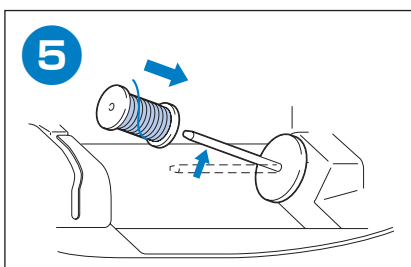
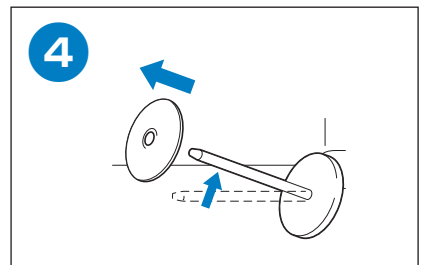
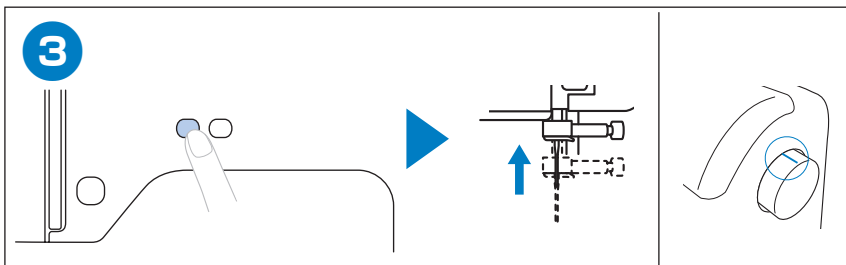
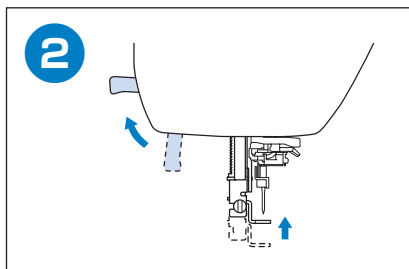
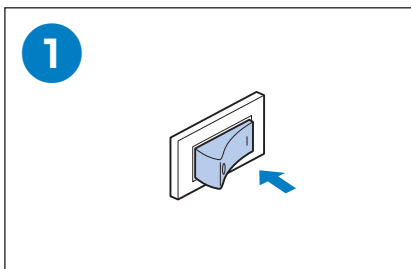
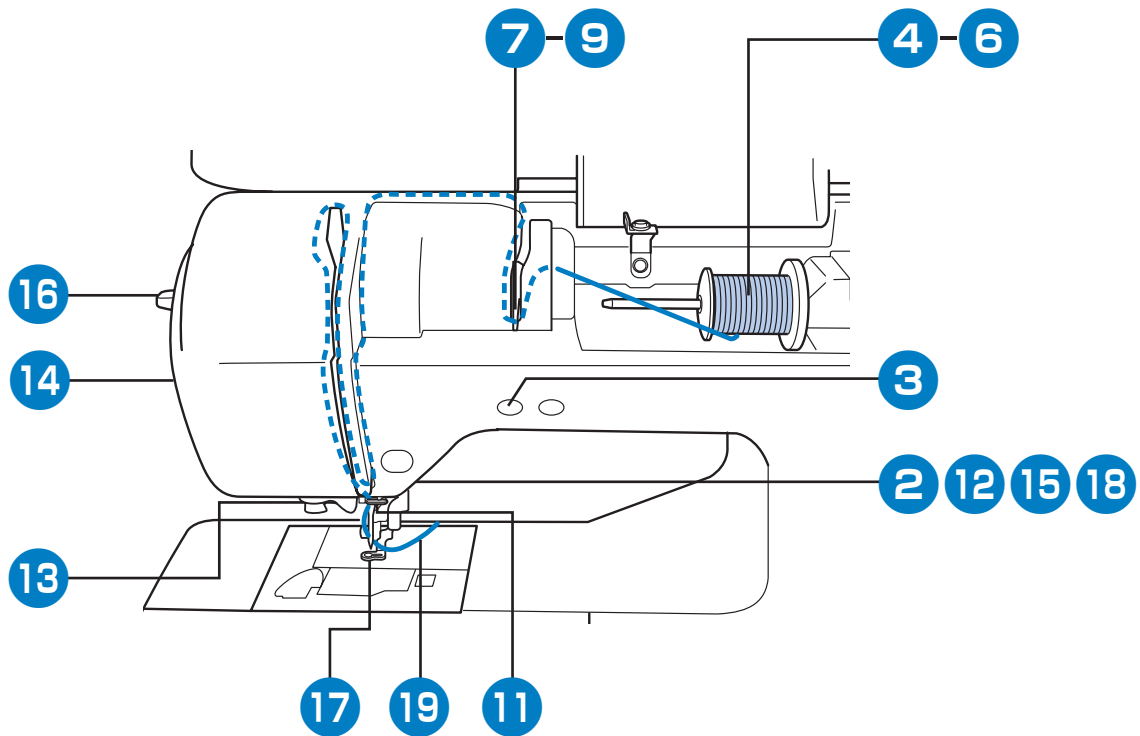

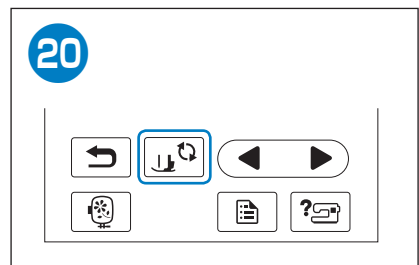
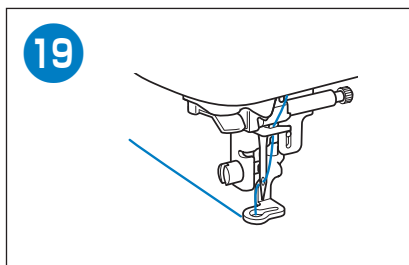
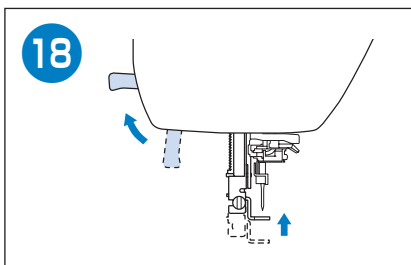
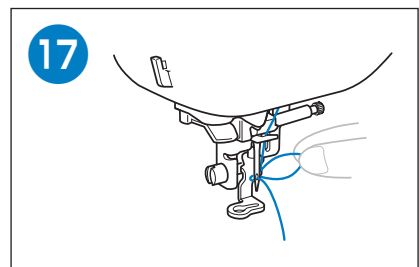
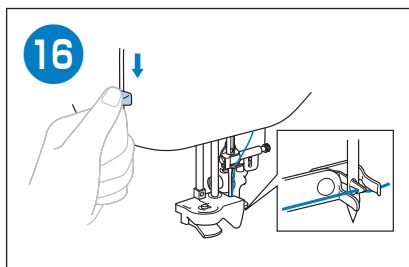
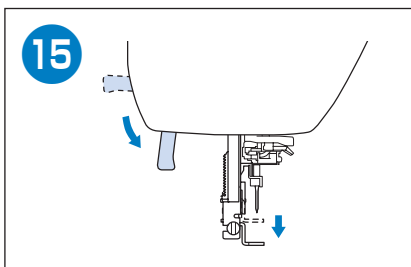
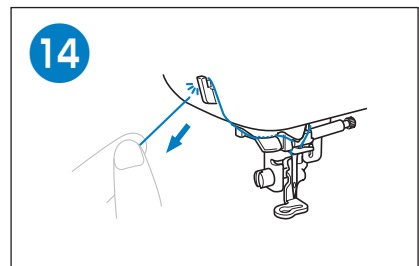
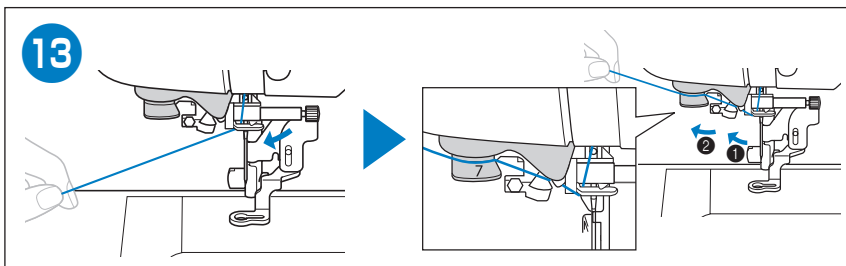
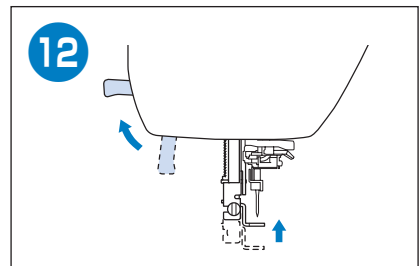
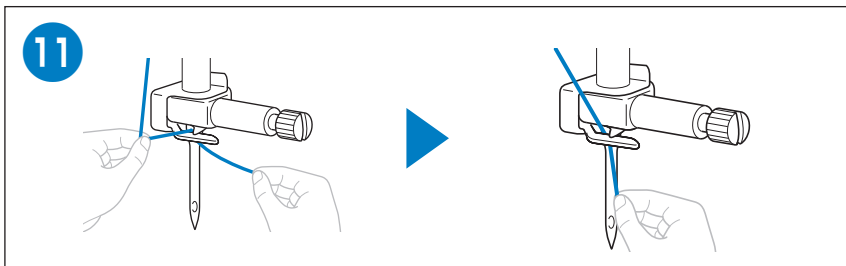
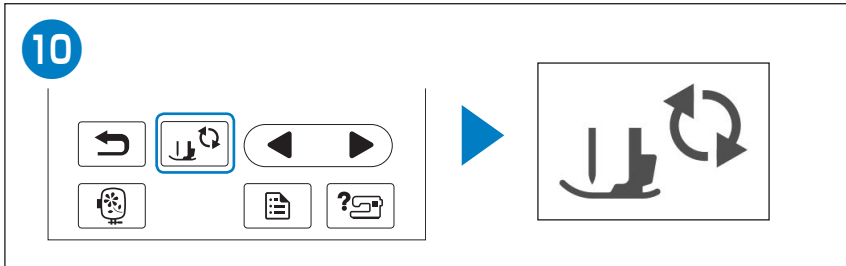
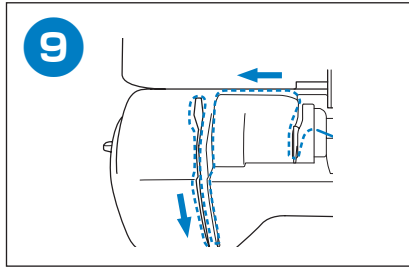
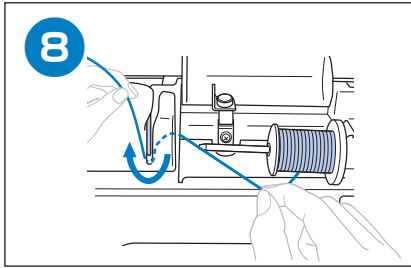



Preparing to Embroider
Vorbereitung zum Sticken
Préparation de la broderie
Vorbereidingen voor borduren
Preparativi per il ricamo
Preparativos para bordar
Preparação para bordar
Подготовка к вышиванию

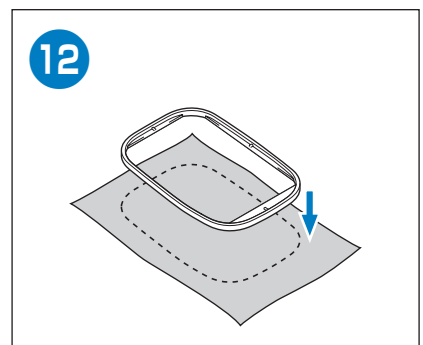
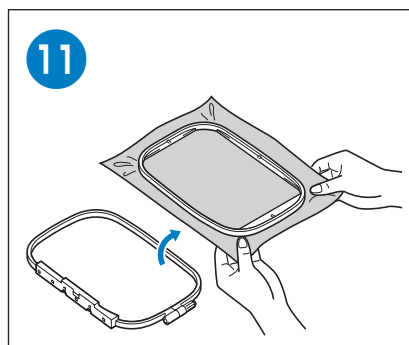
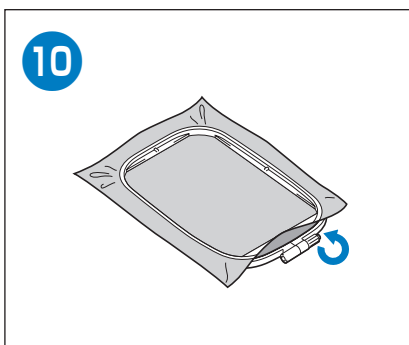
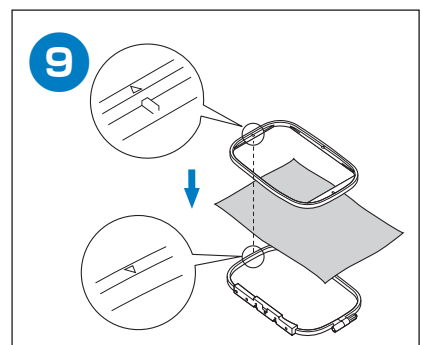
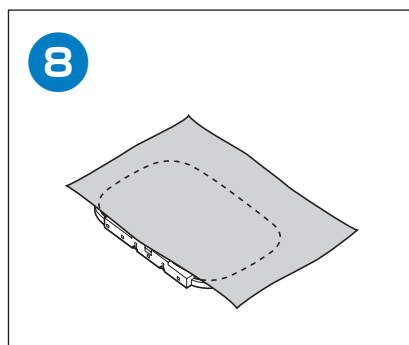
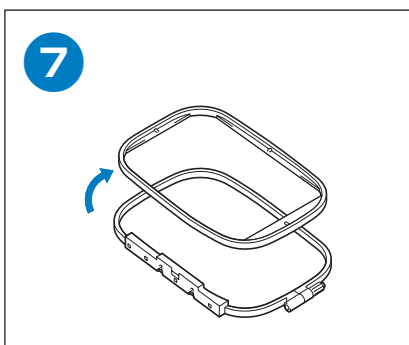
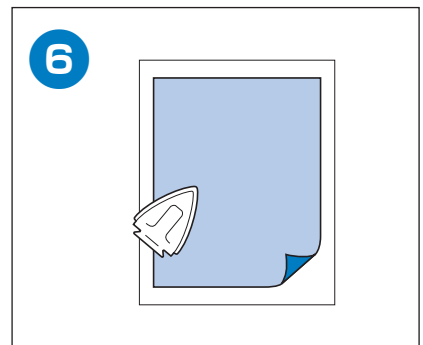
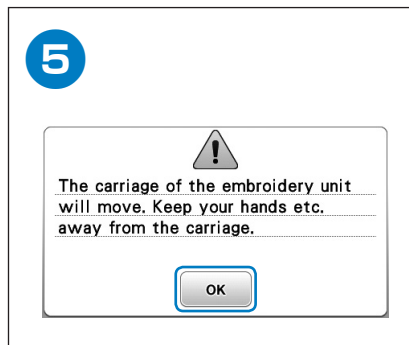
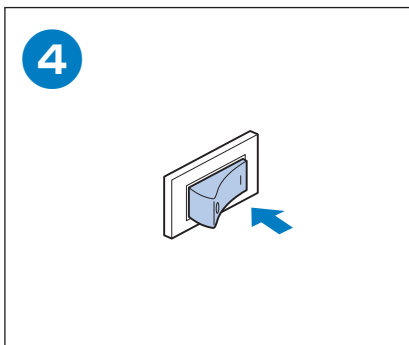
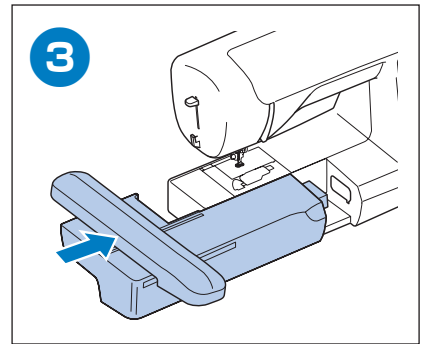
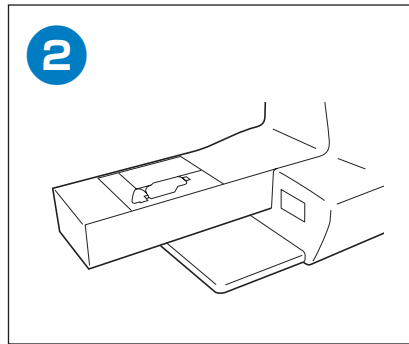
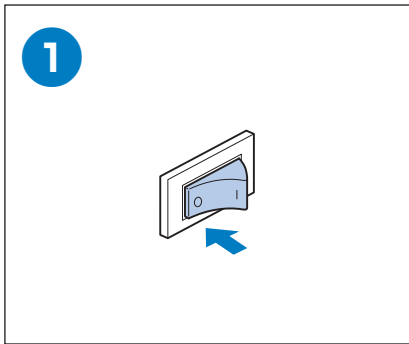

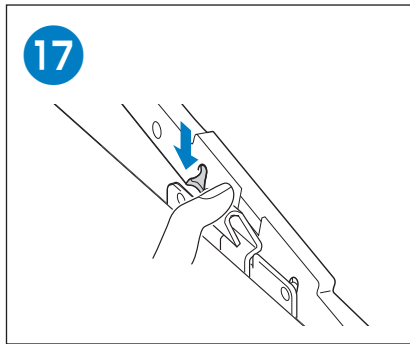
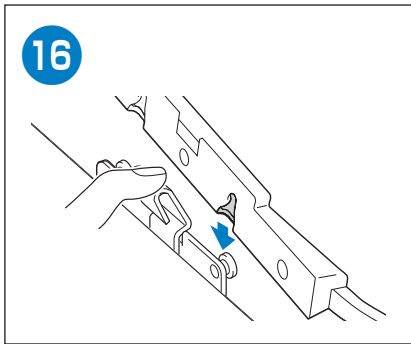
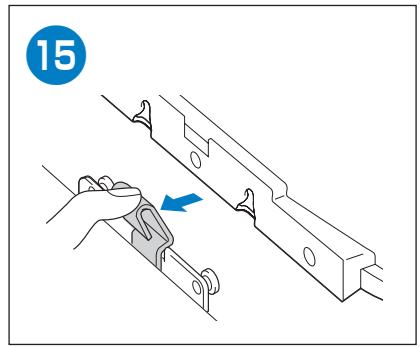
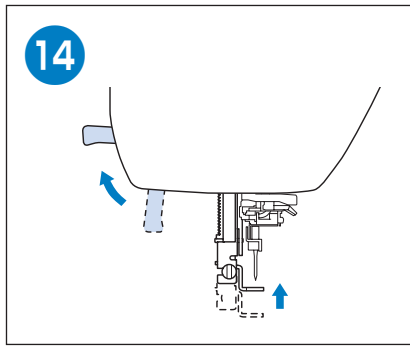
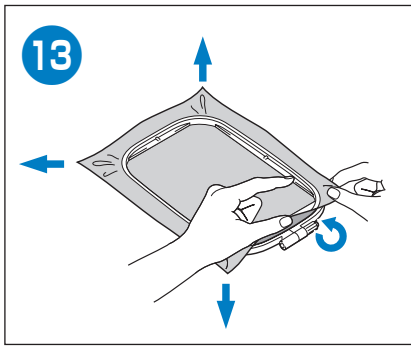



Selecting Embroidery Patterns
Auswählen von Stickmustern
Sélection des motifs de broderie
Borduurpatronen selecteren
Selezione di ricami
Seleccionar patrones de bordado
Seleção de padrões de bordado
Выбор рисунков для вышивания

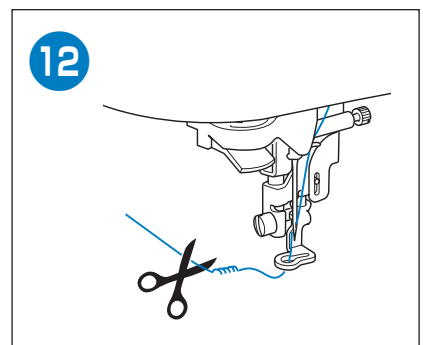
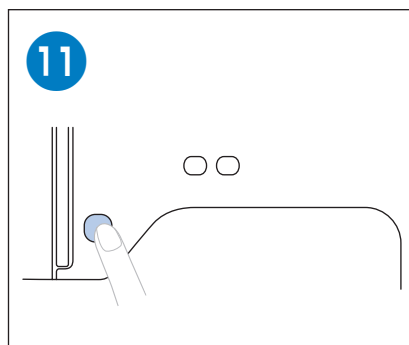
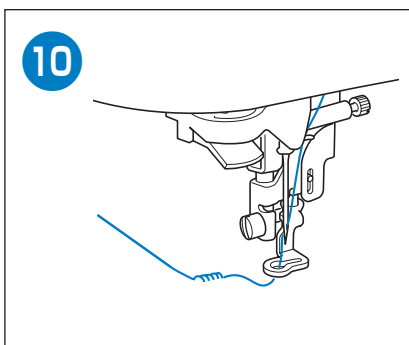
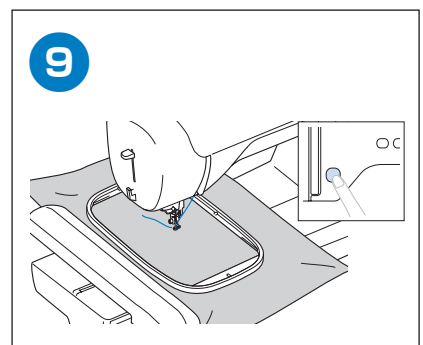
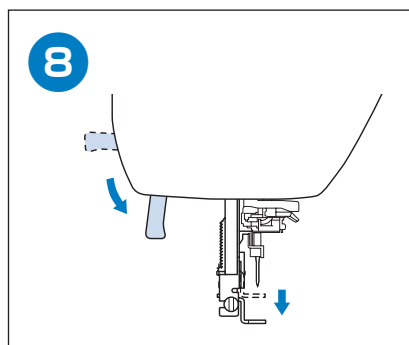
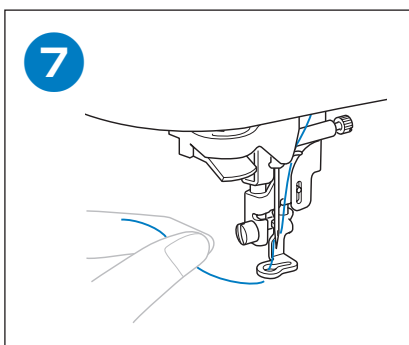
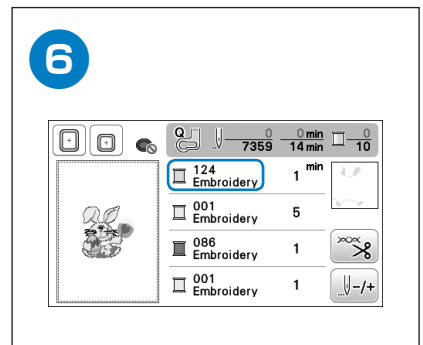
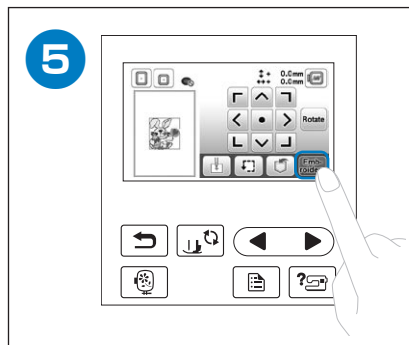
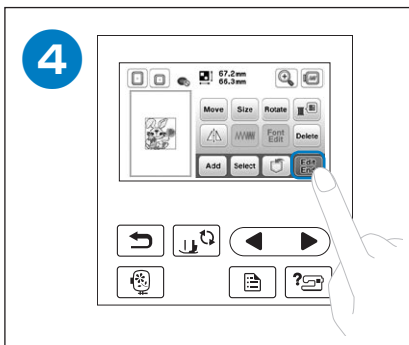
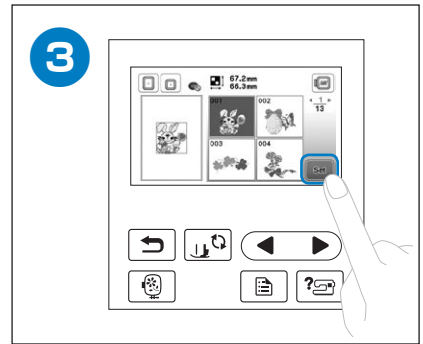
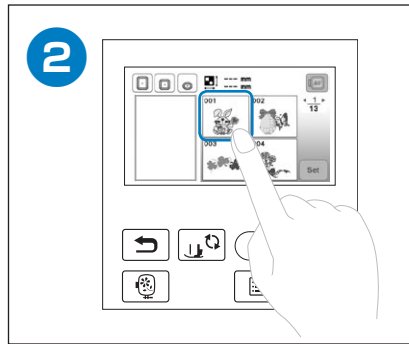
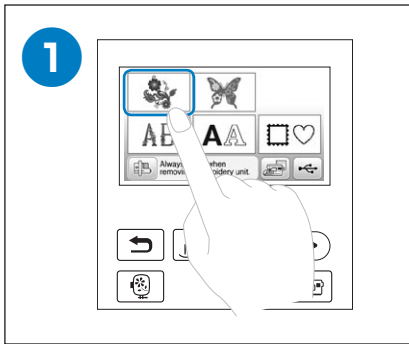

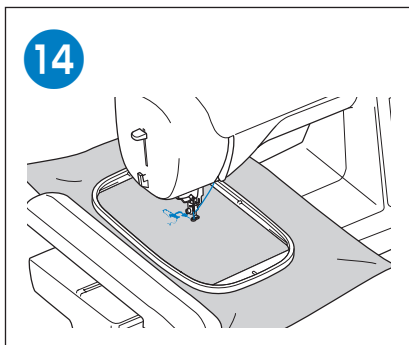
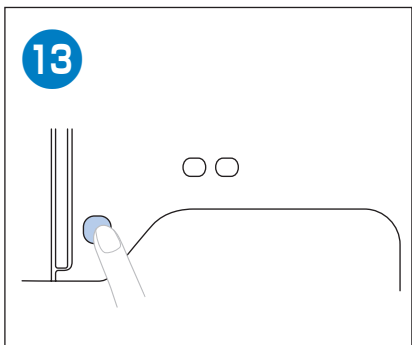

English
German
French
Dutch
Italian
Spanish
Portuguese-BR
Russian
888-L90/L91/L93/K92
Printed in Vietnam



XG5531-001